

PULEGGE



PULLEYS

ZAHNRIEMENSCHLEIBEN

POULIES

POLEAS



Pullegge per cinghie dentate in PA 6:30% FV

Timing belt pulleys in PA 6:30% GF

Zahnriemenscheiben aus PA 6:30% GF

Poulies pour courroies dentées en PA 6:30% FV

Poleas para correas dentadas de PA 6:30% FV



A PASSO METRICO "T"

Metric pitch "T" • Mit metrischer Teilung "T" • Avec pas métrique "T" • De paso métrico "T"

A PASSO METRICO "AT"

Metric pitch "AT" • Mit metrischer Teilung "aT" • Avec pas métrique "AT" • De paso métrico "AT"

CON PASSO IN POLLICI "MXL - XL - L - H"

Inch pitch "MXL - XL - L - H" • Mit Inchteilung "MXL - XL - L - H" • Avec pas en pouces "MXL - XL - L - H" • Con paso en pulgadas "MXL - XL - L - H"

COMPATIBILI "HTD"

"HTD" compatible • "HTD" kompatibel • Compatibles "HTD" • Compatibles "HTD"

COMPATIBILI "RPP"

"RPP" compatible • "RPP" kompatibel • Compatibles "RPP" • Compatibles "RPP"

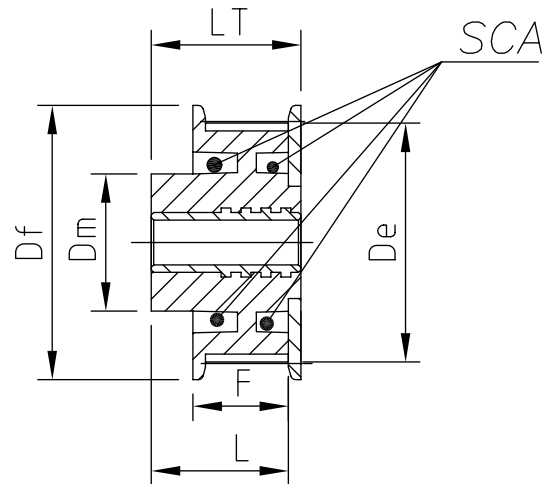
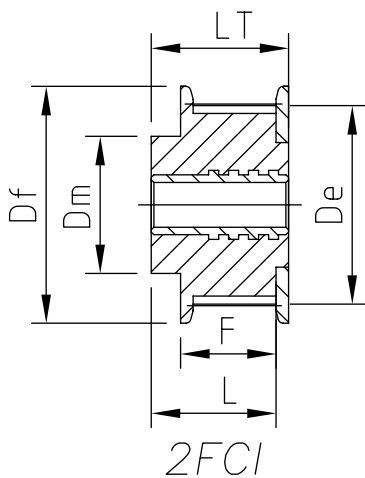
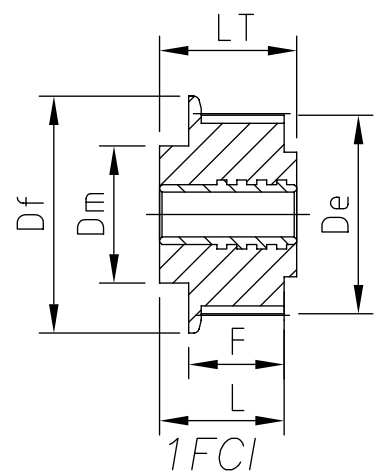
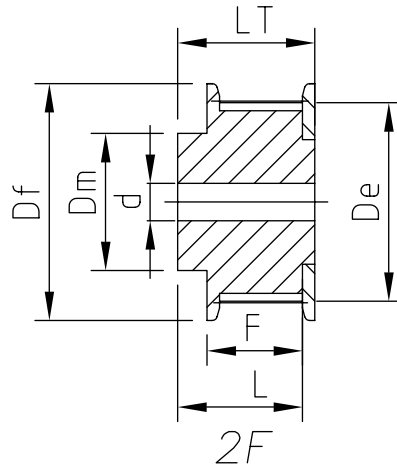
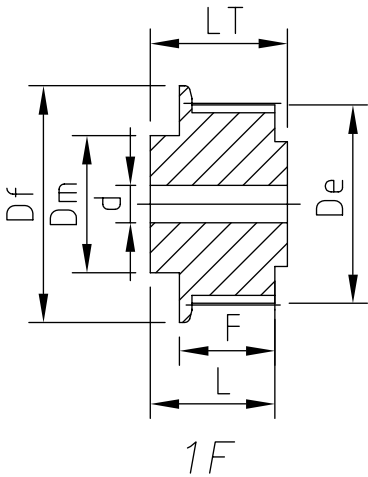

SIMBOLI

SYMBOLS

SYMBOLES

SYMBOLES

SÍMBOLOS

STOCK	=	Disponibilità disegni del prodotto
COD	=	Codice prodotto
TIPO	=	1 F = 1 flangia 2 F = 2 flange
Z	=	N° denti
SCA	=	Alleggerimenti si/no
De	=	Diametro esterno
Df	=	Diametro flangia
Dm	=	Diametro mozzo
F	=	Altezza puleggia
L	=	Altezza puleggia con mozzo
LT	=	Altezza totale puleggia
d	=	Diametro foro

▪ **N.B.: Tutte le nostre pulegge standard hanno 1 flangia**

▪ **N.B.: All our standard pulleys have one flange**

▪ **N.B.: Unsere Standardzahnriemenscheiben haben eine Bordscheibe**

▪ **N.B.: Toutes nos poulies standard ont un flasque**

▪ **Nota: Todas nuestras poleas standard tienen una brida**

STOCK	=	Product drawings available
COD	=	Product code
TIPO	=	1F = 1 Flange 2 F = 2 Flanges
Z	=	Number of teeth
SCA	=	Lightenings yes-no
De	=	External diameter
Df	=	Flange diameter
Dm	=	Hub diameter
F	=	Height of the pulley
L	=	Height of the pulley plus hub
LT	=	Total height of the pulley
d	=	Hole diameter

STOCK	=	Lieferbare Zeichnungen des Produkts
COD	=	Artikelnummer
TIPO	=	1F = 1 Bordscheibe 2 F = 2 Bordscheiben
Z	=	Anzahl der Zähne
SCA	=	Erleichterung Ja/Nein
De	=	Außendurchmesser
Df	=	Durchmesser der Bordscheibe
Dm	=	Durchmesser der Nabe
F	=	Höhe der Zahnriemenscheibe
L	=	Gesamthöhe der Zahnriemenscheibe
LT	=	Höhe der Zahnriemenscheibe mit Nabe
d	=	Bohrungsdurchmesser

STOCK	=	Les dessins des produits sont disponibles
COD	=	Code du produit
TIPO	=	1F = 1 Flasque 2 F = 2 Flasques
Z	=	Nombre de dents
SCA	=	Allègements oui-non
De	=	Diamètre extérieur
Df	=	Diamètre du flasque
Dm	=	Diamètre du moyeu
F	=	Hauteur de la poulie
L	=	Hauteur de la poulie avec moyeu
LT	=	Hauteur totale de la poulie
d	=	Diamètre du trou

STOCK	=	Disponibilidad diseños del producto
COD	=	Código producto
TIPO	=	1F = 1 brida 2 F = 2 bridas
Z	=	N° dientes
SCA	=	Aligeramientos si/no
De	=	Diámetro externo
Df	=	Diámetro brida
Dm	=	Diámetro cubo
F	=	Altura polea
L	=	Altura polea con cubo
LT	=	Altura total polea
d	=	Diámetro agujero

CONFRONTO TRA DIFFERENTI CONFIGURAZIONI DI CINGHIE

COMPARISON OF DIFFERENT BELT CONFIGURATIONS
 VERGLEICH UNTER VERSCHIEDENEN RIEMENGESTALTUNGEN
 COMPARAISON ENTRE LES DIFFERENTES CONFIGURATIONS DES COURROIES
 COMPARACIÓN ENTRE DIFERENTES CONFIGURACIONES DE CORREAS

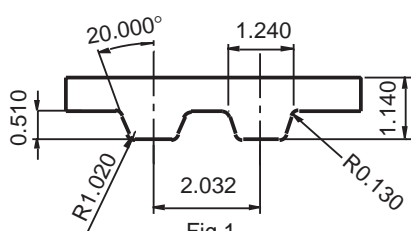

Fig.1
 Passo 2.032mm (MXL)

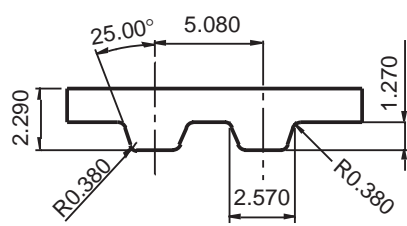

Fig.2
 Passo 5.080mm (XL)

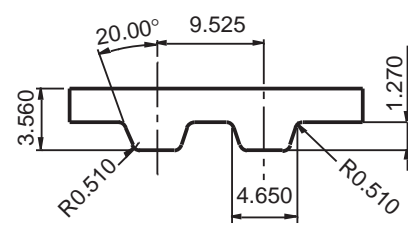

Fig.3
 Passo 9.525mm (L)

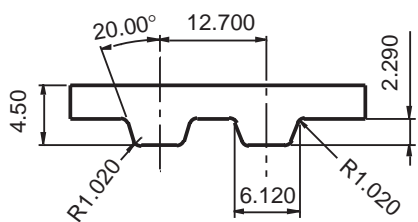

Fig.4
 Passo 12.700mm (H)

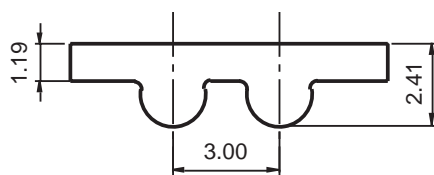

Fig.5
 Passo 3.00mm (HTD)

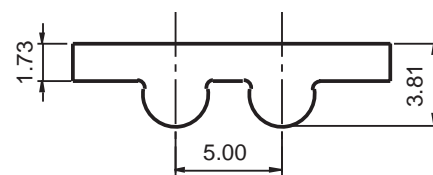

Fig.6
 Passo 5.00mm (HTD)

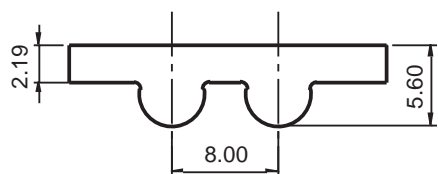

Fig.7
 Passo 8.00mm (HTD)

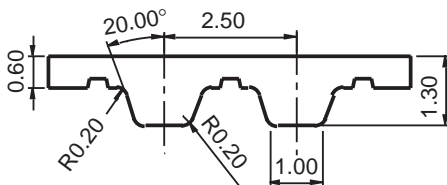

Fig.8
 Passo 2.50mm (T)

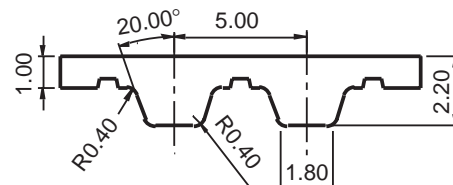

Fig.9
 Passo 5.00mm (T)

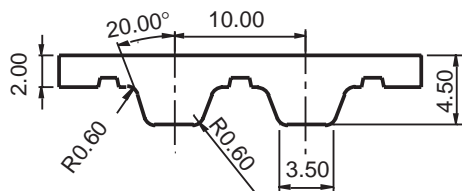

Fig.10
 Passo 10.00mm (T)

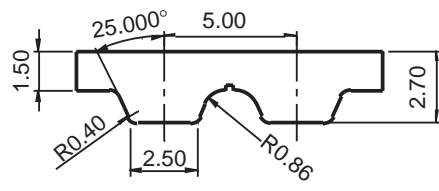

Fig.11
 Passo 5.00mm (AT)

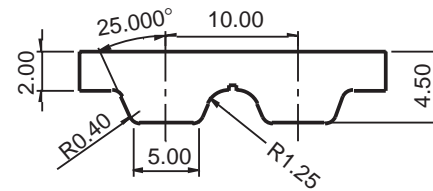

Fig.12
 Passo 10.00mm (AT)

Tensione di funzionamento ammessa per varie larghezze della cinghia

(in kg. non corretta per la perdita di forza centrifuga)

Working tension allowed for different belt widths

(in kg. not suitable due to the loss of centrifugal force)

Zulässige Betriebsspannung für verschiedene Riemenbreiten

(in Kg. nicht korrekt für Schleuderkraftverlust)

Tension de fonctionnement admise pour les différentes largeurs de la courroie

(en Kg. non correcte pour la perte de force centrifuge)

Tensión de funcionamiento admitida para varios anchos de la correa

(en Kg. no correcta por la pérdida de fuerza centrifuga)

Illustrazione Figure Bild Illustration Ilustración	Tipo di cinghia Belt type Riementyp Type de courroie Tipo de correa	Passo Pitch / Teilung Pas / Paso		Tensione di funzionamento ammessa kg/25 mm di larghezza Working tension allowed for kg/25 mm of width Zulässige Betriebsspannung der Breite kg/25 mm Tension de fonctionnement admise kg/25 mm de largeur Tensión de funcionamiento admitida kg/25 mm de ancho	Velocità centrifuga Centrifugal speed Zentrifugalgeschwindigkeit Vitesse centrifuge Velocidad centrifuga
		mm	inch		
1	MXL	2.032	0.080	14.52	10 x 10 ⁻⁹
2	XL	5.08	0.200	18.6	27 x 10 ⁻⁹
3	L	9.525	0.375	24.95	38 x 10 ⁻⁹
4	H	12.7	0.500	63.5	53 x 10 ⁻⁹
5	HTD	3	0.118	27.22	15 x 10 ⁻⁹
6	HTD	5	0.197	45.36	21 x 10 ⁻⁹
7	HTD	8	0.315	62.6	34 x 10 ⁻⁹
8	T	2.5	-	14.52	-
9	T	5	-	18.6	-
10	T	10	-	24.95	-
11	AT	5	-	18.6	-
12	AT	10	-	24.95	-

Tipo di cinghia Belt type Riementyp Type de courroie Tipo de correa		MXL	XL	L	H	HTD		T			AT		
Passo metrico Metric pitch Metrische Teilung Pas métrique Paso métrico		2.032	5.08	9.525	12.7	3	5	2.5	5	10	5	10	
Larghezza cinghia - Belt width - Riemenbreite Largeur de la courroie - Ancho de la correa	3mm (1/8")	1.13						1.59					
	4mm (.157)												
	4.5mm (3/16")	2.04	2.27										
	16mm (.630)						3.63						
	6mm (.236)							2.95	3.4		3.4		
	6mm (1/4")	3.18	3.63				5.44						
	8mm (5/16")	3.9	4.54										
	9.5mm (3/8")	4.63	5.44	7.26			7.94	14.74	4.94	5.94		5.94	
	10mm (.394)						8.62	15.42					
	11mm (7/16")	5.49	6.8	9.07									
	12.5mm (1/2")	6.67	8.16	10.89	26.76	11.79	21.09						
	14mm (9/16")	7.8	9.53	12.7	31.75								
	15mm (.591)						14.06	24.95					
	16mm (5/8")	8.57	10.89	14.06	36.29								
	19mm (3/4)	10.16	13.15	17.7	44.91	19.5	32.66		9.98	12.93	9.98	12.93	
	20mm (.787)					20.4	34.47						
	22mm (7/8")	12.47	15.88	21.32	54.43	23.13	39.01						
25mm (.984)					26.76	44.45			24.95		24.95		
25mm (1")		18.6	24.95	63.5	27.22	45.36			32.66		32.66		
32mm (1.26)													

Diametri minimi della puleggia consigliati in funzione dei giri

Suggested minimum pulley diameters according to revs

Von den Umdrehungen abhängig empfehlende mindeste Zahnriemenscheibendurchmesser

Diamètres minimum de la poulie conseillés en fonction des tours

Diámetros mínimos de la polea recomendados en función de las revoluciones

Tipo di cinghia Belt type Riementyp Type de courroie Tipo de correa	Passo Pitch Teilung Pas Paso		RPM	Minimo suggerito Suggested minimum / Vorgeschlagenes Minimum Ce qui est conseillé au minimum / Mínimo recomendado		
	MM	INCH		N. di denti N. of teeth Anzahl der Zähne Nombre de dents N° de dientes	Diametro primitivo Pitch diameter / Teilungsdurchmesser Diamètre du pas / Diámetro del paso	
					MM	INCH
MXL	2.03	0.080	10000	14	9.1	.357
			7500	12	7.8	.306
			5000	11	7.1	.280
			3500	10	6.5	.255
XL	5.8	0.200	3500	12	19.4	.764
			1750	11	17.8	.700
			1160	10	16.2	.637
L	9.5	0.375	3500	16	48.5	1.910
			1750	14	42.4	1.671
			1160	12	36.4	1.432
H	12.7	0.500	3500	18		3.182
			1750	16		2.865
			1160	14		2.546
TRUE METRIC HDT	3	0.118	3500	15		.752
			1750	14		.677
			1160	12		.639
	5	0.197	3500	15		
			1750	14		
			1160	12		
	8	0.315	3500	18	81.5	3.208
			1750	16	71.3	2.807
			1160	15	61.1	2.406
TRUE METRIC T SERIE	2.5	-	3600	14		
			1800	12		
			1200 UP TO 2000	10		
	5	-	3600	14		
			1800	12		
			1200 UP TO 2000	10		
10	-	3600	15			
		1800	14			
		1200 UP TO 2000	12			
TRUE METRIC AT	5	-	3600	14		
			1800	12		
	10	-	1200 UP TO 2000	10		
			3600	15		
			1800	14		
			1200 UP TO 2000	12		

N.B.: Pulegge più piccole possono essere usate sacrificando la durata della cinghia.

N.B.: Smaller pulleys can be used even if the timing belt life could be shorter.

N.B.: Kleinere Zahnriemenscheiben können verwendet werden, auch wenn die Lebensdauer der Zahnriemen kürzer sein wird.

N.B.: Les poulies ayant un diamètre inférieur peuvent être employées, mais au détriment de la durée de la courroie.

N.B.: Poleas más pequeñas se pueden utilizar sacrificando la duración de la correa.

Comparazione delle prestazioni

dei vari materiali

Performance comparison of various materials

Leistungsvergleich der verschiedenen Werkstoffe

Comparaison des performances des différents matériaux

Comparacion de las prestaciones de los varios materiales

SIMBOLI

SYMBOLS

SYMBOLE

SYMBOLES

SIMBOLOS

E	=	eccellente excellent ausgezeichnet excellent excelente
G	=	buono good gut bon bueno
F	=	discreto fair befriedigend assez bon suficiente
P	=	scarso poor ungenügend faible escaso

Requisiti della cinghia Belt requirements Riemenanforderungen Qualités requises pour la courroie Requisitos de la correa	Nylon Nylon Nylon Nylon Nylon	Acciaio Steel Stahl Acier Acero
Funzionamento con puleggia di piccolo diametro Working with a small diameter pulley Betrieb mit Zahnriemenscheibe mit kleinem Durchmesser Fonctionnement avec une petite poulie Hacer funcionar con una pequeña polea	E	P
Alta velocità della puleggia High speed of the pulley Hohe Geschwindigkeit der Zahnriemenscheibe Vitesse élevée de la poulie Alta velocidad de la polea	E	P
Carico ad impulso ad alta intermittenza High intermittent shock loading Hohe aussetzende Impulsbelastung Charge à impulsion par intermittence élevée Carga con impulsión de elevada intermitencia	F	G
Assorbimento della vibrazione Vibration absorption Schwingungsabsorption Absorption de la vibration Absorción de la vibración	E	P
Coppia alta velocità bassa High torque at low speed Hohes Drehmoment mit niedriger Geschwindigkeit Couple à vitesse peu élevée Torsión elevada velocidad baja	P	E
Con basso allungamento della cinghia Low belt stretch Mit niedriger Riemendehnung Allongement peu élevé de la courroie Bajo alargamiento de la correa	P	E
Stabilità dimensionale Dimensional stability Masstabilität Stabilité dimensionnelle Estabilidad de dimensiones	P	E
Alta temperatura >185°F High temperature >185°F Hohe Temperatur >185°F Température élevée >185°F Alta temperatura >185°F	P	E
Bassa temperatura > -20° Low temperature > -20° Niedrige Temperatur > -20° Basse température > -20° Baja temperatura > -20°	F	E
Buono accoppiamento della cinghia col dente Fitting between belt and tooth Gute Kupplung des Riemens mit dem Zahn Bon couplage de la courroie avec la dent Buen acoplamiento de la correa con el diente	E	P
Rapido funzionamento di start e stop Rapid start-stop operation Schneller Betrieb von Start und Stop Fonctionnement rapide du départ et de l'arrêt Rápido funcionamiento de start y stop	G	E
Elasticità richiesta nella cinghia Required belt elasticity Gebrauchte Elastizität des Riemens Élasticité requise dans la courroie Elasticidad requerida en la correa	E	P

Causa di rottura della cinghia e rimedi

Causes of braking of the bealt and possible solutions

Bruchursachen des Riemens und lösungen

Causes de rupture de la courroie et solutions

Causa de rotura de la correa y remedios

Inconveniente Defects	Causa Causes	Rimedio Solutions
Usura eccessiva dei fianchi (elementi tensili scoperti) Excessive wearing of the sides (wearing of the outer plastic coating)	Cattivo allineamento o assi di rotazione non rigidi. Flangia scorrettamente saldata Wrong alignment or non-rigid rotation axes. Wrong welding of the flange	Controllare l'allineamento o la saldatura, oppure fissare gli alberi Check the alignment or the welding, or fix the shafts
Usura della protezione sul lato di lavoro del dente della cinghia Wearing of the outer plastic coating covering the working side of the belt tooth	Carico eccessivo e/o cinghia eccessivamente tesa. Puleggia stampata male Overloading and/or excessive belt tightening, wrong moulding of the pulley	Aumentare la capacità di carico della cinghia e/o ridurre la tensione della cinghia. Sostituire la puleggia Increase the loading capacity of the belt and/or reduce belt tension. Change the pulley
Screpolatura nella copertura in cloroprene Cracking of the coating in chloroprene	Esposizione a temperatura eccessivamente bassa (al di sotto di -30°) Exposure to extremely low temperatures (below -30°)	Eliminare le condizioni di bassa temperatura oppure consultare il nostro Ufficio Tecnico per cinghie speciali Try to increase the temperature or ask our Technical Dept. for special belts
Rammollimento del rivestimento in cloroprene Softening of the coating in chloroprene	Esposizione a calore eccessivo (oltre i 90°) Exposure to extremely high temperatures (over 90°)	Eliminare le alte temperature oppure consultare il nostro Ufficio Tecnico per cinghie speciali Try to reduce the temperature or ask our Technical Dept. for special belt
Apparente rilassamento della cinghia Apparent softening of the belt tension	Diminuzione dell'interesse e/o montaggio non sufficientemente rigido Reduction of the centre distance and/or non-rigid assembling	Tendere di nuovo la cinghia e/o irrigidire la posizione degli assi Stretch the belt again and/or stiffen the position of the axes
Rottura degli elementi in tensione Braking of tension elements	Carico eccessivo e/o cinghia eccessivamente tesa. Diametro eccessivamente piccolo della puleggia Overloading and/or excessive belt tension, the diameter of the pulley might be too small	Aumentare la capacità di carico della cinghia e/o ridurre la tensione della cinghia. Aumentare il diametro della puleggia oppure usare un diametro più piccolo Increase to loading capacity of the belt and/or reduce belt tension. Increase the diameter of the pulley or use a pulley with a smaller diameter
Usura irregolare di alcuni denti della cinghia Irregular wearing of some belt teeth	Salto di un dente. Ambiente troppo sporco Jump of a tooth. Excessively dirty environment	Aumentare la tensione della cinghia Increase belt tension
Usura eccessiva della puleggia Excessive wearing of the pulley	Carico eccessivo e/o cinghia eccessivamente tesa. Durezza insufficiente del materiale della puleggia Overloading and/or excessive belt tension. Low hardness of the material	Aumentare la capacità di carico della cinghia e/o ridurre la tensione della cinghia. Indurire la superficie della puleggia e/o usare un materiale più duro Increase the loading capacity of the belt and/or reduce belt tension. Harden the surface of the pulley and/or use a stronger material
Perdita delle flange, consumo delle flange Loss of the flanges, wearing of the flanges	Montaggio scorretto delle flange. Allineamento scorretto Wrong assembling of the flanges. Wrong alignment	Installare di nuovo correttamente le flange. Correggere l'allineamento Re-assemble the franges. Correct the alignment
Eccessivo rumore della trasmissione Excessive noise during chain drive	Allineamento scorretto. Carico eccessivo e/o cinghia eccessivamente tesa. Diametro eccessivamente piccolo della puleggia. Profilo del dente troppo preciso Wrong alignment. Overloading and/or excessive belt tension. The diameter of the pulley might be too small. Extremely precise tooth profile	Correggere l'allineamento. Aumentare la capacità di carico della cinghia e/o ridurre la tensione della cinghia. Aumentare il diametro della puleggia Correct the alignment. Increase the loading capacity of the belt and/or reduce belt tension. Increase the diameter of the pulley
Vibrazione ramo lento Vibration of the slacked branch	Tensione troppo ridotta Extremely low belt tension	Aumentare la tensione della cinghia Increase belt tension
Vibrazione ramo teso Vibration of the stretched branch	Tensione eccessiva Extremely high belt tension	Ridurre la tensione della cinghia Reduce belt tension

<p style="text-align: center;">Nachteile Problèmes Inconveniente</p>	<p style="text-align: center;">Ursachen Causes Causa</p>	<p style="text-align: center;">Lösungen Solutions Remedio</p>
<p>Übermäßiger Verschleiß der Seiten (Verschleiß der Äußerbekleidung) Usure excessive des flancs (détérioration du revêtement extérieur en plastique) Desgaste excesivo de los costados (elementos en tensión descubiertos)</p>	<p>Falsche Anreihung oder unstarre Umdrehungsachsen. Falsch geschweißte Bordscheibe Mauvais alignement ou axes de rotation pas rigides. Flasque soudée incorrectement Mal funcionamiento o ejes de rotación no rígidos. Brida no soldada correctamente</p>	<p>Überprüfen Sie die Anreihung oder die Schweißung oder befestigen Sie die Wellen Contrôler l'alignement ou la soudure, ou fixer les arbres Controlar la alineación o la soldadura, o fijar los ejes</p>
<p>Verschleiß der Äußerbekleidung auf der Antriebsseite des Riemens Usure du revêtement sur le côté de marche de la dent de la courroie Desgaste de la protección en el lado de trabajo del diente de la correa</p>	<p>Überlastung und/oder übermäßige Spannung des Riemens. Falsch gepresste Zahnriemenscheibe Charge excessive et/ou courroie excessivement tendue, poulie mal moulée Carga excesiva y/o correa demasiado tensa, polea mal moldeada</p>	<p>Erhöhen Sie die Belastungsfähigkeit des Riemens und/oder entspannen Sie den Riemen. Ersetzen Sie die Zahnriemenscheibe Augmenter la capacité de charge de la courroie et/ou réduire la tension de la courroie, remplacer la poulie Aumentar la capacidad de carga de la correa y/o reducir la tensión de la correa. Cambiar la correa</p>
<p>Verschleiß der Äußerbekleidung aus Chloropren Déchirure de la couverture en chloroprène Agrietamiento en el revestimiento de cloropreno</p>	<p>Aussetzung zu niedrigen Temperaturen (unter -30°) Exposition à température excessivement basse (inférieure à -30°) Exposición a temperatura demasiado baja (por debajo de -30°)</p>	<p>Erhöhen Sie die Temperatur oder fragen Sie unsere technische Abteilung nach Sonderriemen Éliminer les conditions de basse température ou consulter notre Bureau Technique pour des courroies spéciales Eliminar las condiciones de baja temperatura o consultar con nuestro Departamento Técnico para correas especiales</p>
<p>Schwächung der Äußerbekleidung aus Chloropren Ramollissement de la couverture en chloroprène Ablandamiento del revestimiento de cloropreno</p>	<p>Aussetzung zu hohen Temperaturen (über 90°) Exposition à une chaleur excessive (supérieure à 90°) Exposición a calor excesivo (más de 90°)</p>	<p>Erniedrigen Sie die Temperatur oder fragen Sie unsere technische Abteilung nach Sonderriemen Éliminer les hautes températures ou consulter notre Bureau Technique pour des courroies spéciales Eliminar las altas temperaturas o consultar con nuestro Departamento Técnico para correas especiales</p>
<p>Scheinbare Schwächung des Riemens Apparent relâchement de la courroie Aparente aflojamiento de la correa</p>	<p>Verkleinerung des Achsenabstands und/oder unstarre Zusammenbau Diminution de l'entre-axes et/ou montage pas assez rigide Disminución de la distancia entre ejes y/o montaje no suficientemente rígido</p>	<p>Spannen Sie den Riemen wieder und/oder verspannen Sie die Stellung der Achsen Tendre à nouveau la courroie et/ou raidir la position des axes Tensar de nuevo la correa y/o dar rigidez a la posición de los ejes</p>
<p>Bruch der Spannungselemente Rupture des éléments de tension Rotura des los elementos de tensión</p>	<p>Überlastung und/oder übergespannter Riemen. Die Zahnriemenscheibe kann einen äußerst kleinen Durchmesser haben Charge excessive et/ou courroie excessivement tendue, diamètre de la poulie trop petit Carga excesiva y/o correa demasiado tensa, diámetro demasiado pequeño de la polea</p>	<p>Erhöhen Sie die Belastungsfähigkeit des Riemens und/oder entspannen Sie den Riemen. Vergrößern Sie den Durchmesser der Zahnriemenscheibe oder verwenden Sie eine Zahnriemenscheibe mit einem kleineren Durchmesser Augmenter la capacité de charge de la courroie et/ou réduire la tension de la courroie. Augmenter le diamètre de la poulie ou utiliser un diamètre plus petit Aumentar la capacidad de carga de la correa y/o reducir la tensión de la correa. Aumentar el diámetro de la polea o usar un diámetro más pequeño</p>
<p>Unregelmäßiger Verschleiß einiger Zähne des Riemens Usure irrégulière de certaines dents de la courroie Desgaste irregular de algunos dientes de la correa</p>	<p>Sprung eines Zahns. Schmutzige Antriebsbedingungen Saut d'une dent. Milieu trop sale Salto de un diente. Ambiente demasiado sucio</p>	<p>Erhöhen Sie die Spannung des Riemens Augmenter la tension de la courroie Aumentar la tensión de la correa</p>
<p>Übermäßiger Verschleiß des Riemens Usure excessive de la poulie Desgaste excesivo de la polea</p>	<p>Überlastung und/oder übergespannter Riemen. Unzureichende Härte der Zahnriemenscheibe Charge excessive et/ou courroie trop tendue. Dureté insuffisante du matériel de la poulie Carga excesiva y/o correa demasiado tensa. Dureza insuficiente del material de la polea</p>	<p>Erhöhen Sie die Belastungsfähigkeit des Riemens und/oder entspannen Sie den Riemen. Verhärten Sie die Oberfläche der Zahnriemenscheibe und/oder verwenden Sie ein härteres Material Augmenter la capacité de charge de la courroie et/ou réduire la tension de la courroie. Durcir la surface de la poulie et/ou utiliser un matériel plus dur Aumentar la capacidad de carga de la correa y/o reducir la tensión de la correa. Endurecer la superficie de la polea y/o usar un material más duro</p>
<p>Verlust der Bordscheiben. Verschleiß der Bordscheiben Perte des flasques. Usure des flasques Pérdida de la bridas. Desgaste de las bridas</p>	<p>Falscher Zusammenbau der Bordscheiben. Falsche Anreihung Mauvais montage des brides. Alignement pas correct Montaje incorrecto de las bridas. Alineación incorrecta</p>	<p>Bauen Sie neu die Bordscheiben zusammen. Korrigieren Sie die Anreihung Installer à nouveau correctement les flasques. Corriger l'alignement Instalar de nuevo correctamente las bridas. Corregir la alineación</p>
<p>Übermäßiger Lärm des Antriebs Bruit excessif de la transmission Ruido excesivo en la transmisión</p>	<p>Falsche Anreihung. Überlastung und/oder übergespannter Riemen. Die Zahnriemenscheibe kann einen zu kleinen Durchmesser oder ein zu präzises Zahnprofil haben Alignement pas correct, excessif et/ou courroie trop tendue, diamètre de la poulie excessivement petit, profil de la dent trop précis Alineación incorrecta. Carga excesiva y/o correa demasiado tensa. Diámetro demasiado pequeño de la polea. Perfil del diente demasiado preciso</p>	<p>Korrigieren Sie die Anreihung. Erhöhen Sie die Belastungsfähigkeit des Riemens und/oder entspannen Sie den Riemen. Verwenden Sie eine Zahnriemenscheibe mit einem größeren Durchmesser Corriger l'alignement. Augmenter la capacité de charge de la courroie et/ou réduire la tension de la courroie. Augmenter le diamètre de la poulie Corregir la alineación. Aumentar la capacidad de carga de la correa y/o reducir la tensión de la correa. Aumentar el diámetro de la polea</p>
<p>Vibrieren des entspannten Astes Vibration branche molle Vibración ramo lento</p>	<p>Niedrige Spannung Tension trop faible Tensión demasiado reducida</p>	<p>Spannen Sie den Riemen Augmenter la tension de la courroie Aumentar la tensión de la correa</p>
<p>Vibrieren des gespannten Astes Vibration branche tendue Vibración ramo tenso</p>	<p>Übermäßige Spannung Tension excessive Tensión excesiva</p>	<p>Entspannen Sie den Riemen Réduire la tension de la courroie Reducir la tensión de la correa</p>

PULEGGE dentate

a Passo Metrico T

Timing belt pulleys metric pitch T
 Zahnriemenscheiben metrische Teilung T
 Poulies dentées à pas métrique T
 Poleas dentadas de paso métrico T

5

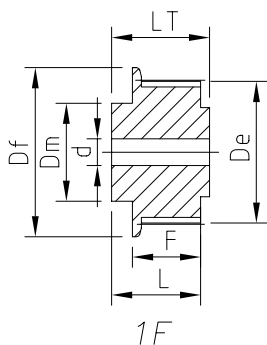

16 T 2,5

PASSO 2,5 mm

PITCH 2,5 mm
 TEILUNG 2,5 mm
 PAS 2,5 mm
 PASO 2,5 mm

LARGHEZZA CINGHIA 6 mm

BELT WIDTH 6 mm
 RIEMENBREITE 6 mm
 LARGEUR DE LA COURROIE 6 mm
 ANCHO DE LA CORREA 6 mm

STOCK	COD	TIPO	Z	SCA	De	Df	Dm	F	L	LT	d
+	PL01Z10	1F	10	no	7,40	12	12	9,5	17,5	19	3
+	PL01Z11	1F	11	no	8,20	12	12	9,5	17,5	19	3
+	PL01Z12	1F	12	no	9,00	12	12	9,5	17,5	19	3
+	PL01Z13	1F	13	no	9,80	12	12	9,5	17,5	19	3
+	PL01Z14	1F	14	no	10,60	15	12	9,5	17,5	19	3
+	PL01Z15	1F	15	no	11,40	15	12	9,5	17,5	19	3
+	PL01Z16	1F	16	no	12,18	16	12	9,5	17,5	19	3
+	PL01Z17	1F	17	no	13,00	16	12	9,5	17,5	19	3
+	PL01Z18	1F	18	no	13,77	18	14	9,5	17,5	19	3
+	PL01Z19	1F	19	no	14,56	18	14	9,5	17,5	19	3
+	PL01Z20	1F	20	no	15,36	20	14	9,5	17,5	19	3
+	PL01Z21	1F	21	no	16,20	20	14	9,5	17,5	19	3
+	PL01Z22	1F	22	no	17,00	22	14	9,5	17,5	19	3
+	PL01Z23	1F	23	no	17,75	22	14	9,5	17,5	19	3
+	PL01Z24	1F	24	no	18,55	24	14	9,5	17,5	19	3
+	PL01Z25	1F	25	no	19,35	24	14	9,5	17,5	19	3
+	PL01Z26	1F	26	no	20,14	26	16	9,5	17,5	19	4
+	PL01Z27	1F	27	no	20,93	26	16	9,5	17,5	19	4
+	PL01Z28	1F	28	no	21,75	28	16	9,5	17,5	19	4
+	PL01Z29	1F	29	no	22,52	28	16	9,5	17,5	19	4
+	PL01Z30	1F	30	no	23,35	30	18	9,5	17,5	19	5
+	PL01Z31	1F	31	no	24,10	30	18	9,5	17,5	19	5
+	PL01Z32	1F	32	no	24,95	32	18	9,5	17,5	19	5
+	PL01Z33	1F	33	no	25,70	32	18	9,5	17,5	19	5
	PL01Z34	1F	34		26,50			9,5	17,5	19	
	PL01Z35	1F	35		27,30			9,5	17,5	19	
	PL01Z36	1F	36		28,10			9,5	17,5	19	
+	PL01Z48	1F	48	no	37,30	44	25	10	17,5	19	5
	PL01Z60	1F	60		47,20			10	17,5	19	

21 T 5

PASSO 5 mm

PITCH 5 mm
TEILUNG 5 mm
PAS 5 mm
PASO 5 mm

LARGHEZZA CINGHIA 10 mm

BELT WIDTH 10 mm
RIEMENBREITE 10 mm
LARGEUR DE LA COURROIE 10 mm
ANCHO DE LA CORREA 10 mm

STOCK	COD	TIPO	Z	SCA	De	Df	Dm	F	L	LT	d
	PL02Z10	1F	10		15,05			15,3	22,0	24	
+	PL02Z12	1F	12	no	18,25	23	10	15,3	22,0	24	4
	PL02Z14	1F	14		21,45			15,3	22,0	24	
+	PL02Z15	1F	15		23,05	28		15,3	22,0	24	
+	PL02Z16	1F	16	no	24,60	32	18	15,3	22,0	24	6
	PL02Z18	1F	18	no	27,80	32	20	15,3	22,0	24	6
+	PL02Z20	1F	20	no	31,00	36	23	15,3	22,0	24	6
	PL02Z22	1F	22		32,25			15,3	22,0	24	8
+	PL02Z24	1F	24		37,34			15,3	22,0	24	8
+	PL02Z25	1F	25	no	38,95	44	26	15,3	22,0	24	8
	PL02Z26	1F	26	no	40,55	44	26	15,3	22,0	24	8
	PL02Z28	1F	28		43,75			15,3	22,0	24	
+	PL02Z30	1F	30		46,90			15,3	22,0	24	
+	PL02Z32	1F	32	no	50,10	54	28	15,3	22,0	24	10
	PL02Z34	1F	34	no	53,27	58	35	15,3	22,0	24	10
	PL02Z35	1F	35		54,85			15,3	22,0	24	
	PL02Z36	1F	36		56,45			15,3	22,0	24	
	PL02Z38	1F	38	no	59,64	64	35	15,3	22,0	24	10
+	PL02Z40	1F	40	si	62,85	66	35	15,3	22,0	24	10
+	PL02Z60	1F	60	si	94,65	100	50	15,3	22,0	24	15
+	PL02Z65	1F	65	si	102,60	108	50	15,3	22,0	24	15
	PL02Z72	1F	72		113,75			15,3	22,0	24	
+	PL02Z120	1F	120	si	190,15			15,3	22,0	24	

27 T 5

PASSO 5 mm

PITCH 5 mm
TEILUNG 5 mm
PAS 5 mm
PASO 5 mm

LARGHEZZA CINGHIA 16 mm

BELT WIDTH 16 mm
RIEMENBREITE 16 mm
LARGEUR DE LA COURROIE 16 mm
ANCHO DE LA CORREA 16 mm

STOCK	COD	TIPO	Z	SCA	De	Df	Dm	F	L	LT	d
	PL03Z12	1F	12		18,25			22	28,0	30	
	PL03Z14	1F	14		21,45			22	28,0	30	
	PL03Z15	1F	15		23,05			22	28,0	30	
	PL03Z16	1F	16		24,60			22	28,0	30	
	PL03Z18	1F	18		27,80			22	28,0	30	
	PL03Z20	1F	20		31,00			22	28,0	30	
	PL03Z22	1F	22		34,25			22	28,0	30	
	PL03Z24	1F	24		37,40			22	28,0	30	
	PL03Z25	1F	25		38,95			22	28,0	30	
	PL03Z28	1F	28		43,75			22	28,0	30	
	PL03Z30	1F	30		46,95			22	28,0	30	
	PL03Z32	1F	32		50,10			22	28,0	30	
	PL03Z35	1F	35		54,86			22	28,0	30	
	PL03Z36	1F	36		56,45			22	28,0	30	
	PL03Z40	1F	40	si	62,85	66	35	22	28,0	30	10

31 T 10

PASSO 10 mm

PITCH 10 mm
TEILUNG 10 mm
PAS 10 mm
PASO 10 mm

LARGHEZZA CINGHIA 16 mm

BELT WIDTH 16 mm
RIEMENBREITE 16 mm
LARGEUR DE LA COURROIE 16 mm
ANCHO DE LA CORREA 16 mm

STOCK	COD	TIPO	Z	SCA	De	Df	Dm	F	L	LT	d
+	PL04Z12	1F	12	no	36,35	42	30	22	32	34	6
+	PL04Z14	1F	14	no	42,70	48	30	22	32	34	8
+	PL04Z15	1F	15	no	45,90	51	30	22	32	34	8
+	PL04Z16	1F	16	no	49,10	55	30	22	32	34	8
+	PL04Z17	1F	17	no	52,29	58	30	22	32	34	8
+	PL04Z18	1F	18	no	55,45	61	40	22	32	34	8
+	PL04Z19	1F	19	no	58,62	64	40	22	32	34	8
+	PL04Z20	1F	20	no	61,80	67	40	22	32	34	12
+	PL04Z21	1F	21	no	64,95	71	40	22	32	34	12
+	PL04Z22	1F	22	no	68,20	75	40	22	32	34	12
+	PL04Z24	1F	24	si	74,75	83	40	22	32	32	12
+	PL04Z25	1F	25	si	77,70	83	40	22	32	34	14
+	PL04Z27	1F	27	si	84,10	90	40	22	32	34	14
+	PL04Z28	1F	28	si	87,50	93	40	22	32	34	14
+	PL04Z30	1F	30	si	93,65	99	50	22	32	34	14
+	PL04Z32	1F	32	si	100,00	105	50	22	32	34	14
	PL04Z35	1F	35		109,55			22	32	34	
	PL04Z36	1F	36		112,75			22	32	34	
	PL04Z40	1F	40		125,45			22	32	34	
	PL04Z48	1F	48		150,95			22	32	34	

40 T 10

PASSO 10 mm

PITCH 10 mm
TEILUNG 10 mm
PAS 10 mm
PASO 10 mm

LARGHEZZA CINGHIA 25 mm

BELT WIDTH 25 mm
RIEMENBREITE 25 mm
LARGEUR DE LA COURROIE 25 mm
ANCHO DE LA CORREA 25 mm

STOCK	COD	TIPO	Z	SCA	De	Df	Dm	F	L	LT	d
	PL05Z12	1F	12		36,35			31	41,0	43	
	PL05Z14	1F	14		42,70			31	41,0	43	
	PL05Z15	1F	15		45,90			31	41,0	43	
+	PL05Z16	1F	16	no	49,08	54	35	31	41,0	43	8
	PL05Z18	1F	18		55,45			31	41,0	43	
+	PL05Z20	1F	20	no	61,80	67	40	31	41,0	43	10
+	PL05Z21	1F	21	si	65,00	67	40	31	41,0	43	10
	PL05Z22	1F	22		68,20			31	41,0	43	
	PL05Z24	1F	24		74,55			31	41,0	43	
	PL05Z25	1F	25	no	77,70			31	41,0	43	
	PL05Z27	1F	27	no	84,10			31	41,0	43	
	PL05Z28	1F	28		87,25			31	41,0	43	
	PL05Z30	1F	30		93,65			31	41,0	43	
	PL05Z32	1F	32		100,00			31	41,0	43	
	PL05Z35	1F	35		109,55			31	41,0	43	
+	PL05Z36	1F	36	si	112,75	119	60	31	41,0	43	14
	PL05Z40	1F	40		125,45			31	41,0	43	

PULEGGE dentate

a Passo Metrico AT

Timing belt pulleys metric pitch AT
Zahnriemenscheiben metrische Teilung AT
Poulies dentées avec pas métrique AT
Poleas dentadas de paso métrico AT

5

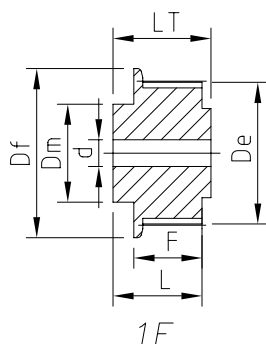

21 AT 5

PASSO 5 mm

PITCH 5 mm
TEILUNG 5 mm
PAS 5 mm
PASO 5 mm

LARGHEZZA CINGHIA 10 mm

BELT WIDTH 10 mm
RIEMENBREITE 10 mm
LARGEUR DE LA COURROIE 10 mm
ANCHO DE LA CORREA 10 mm

STOCK	COD	TIPO	Z	SCA	De	Df	Dm	F	L	LT	d
	PL11Z12	1F	12		18,25			15,3	22	24	
	PL11Z14	1F	14		21,45			15,3	22	24	
	PL11Z15	1F	15		23,05			15,3	22	24	
	PL11Z16	1F	16		24,60			15,3	22	24	
	PL11Z18	1F	18		27,80			15,3	22	24	
	PL11Z20	1F	20		31,00			15,3	22	24	
	PL11Z22	1F	22		34,25			15,3	22	24	
	PL11Z24	1F	24		37,40			15,3	22	24	
	PL11Z25	1F	25		38,95			15,3	22	24	
	PL11Z28	1F	28		43,75			15,3	22	24	
	PL11Z30	1F	30		46,95			15,3	22	24	
	PL11Z32	1F	32		50,10			15,3	22	24	
	PL11Z35	1F	35		54,90			15,3	22	24	
	PL11Z40	1F	40		62,85			15,3	22	24	

27 AT 5

PASSO 5 mm

PITCH 5 mm
TEILUNG 5 mm
PAS 5 mm
PASO 5 mm

LARGHEZZA CINGHIA 16 mm

BELT WIDTH 16 mm
RIEMENBREITE 16 mm
LARGEUR DE LA COURROIE 16 mm
ANCHO DE LA CORREA 16 mm

STOCK	COD	TIPO	Z	SCA	De	Df	Dm	F	L	LT	d
	PL12Z12	1F	12		17,85			22	28	30	
	PL12Z14	1F	14		21,04			22	28	30	
	PL12Z15	1F	15		22,63			22	28	30	
+	PL12Z16	1F	16	no	24,22	32	20	22	28	30	6
	PL12Z18	1F	18		27,40			22	28	30	
+	PL12Z20	1F	20	no	30,60	36	24	22	28	30	6
	PL12Z22	1F	22		33,77			22	28	30	
	PL12Z24	1F	24		36,95			22	28	30	
	PL12Z25	1F	25		38,54			22	28	30	
	PL12Z26	1F	26		40,14			22	28	30	
	PL12Z27	1F	27		41,73			22	28	30	
	PL12Z28	1F	28		43,32			22	28	30	
+	PL12Z30	1F	30	no	46,50	51	30	22	28	30	8
	PL12Z32	1F	32		49,68			22	28	30	
	PL12Z35	1F	35		54,46			22	28	30	
	PL12Z40	1F	40		62,42			22	28	30	
+	PL12Z60	1F	60	si	94,25	99	50	22	28	30	18
+	PL12Z106	1F	106	si	167,46	175,0	60	22	28	30	20

31 AT 10

PASSO 10 mm

PITCH 10 mm
TEILUNG 10 mm
PAS 10 mm
PASO 10 mm

LARGHEZZA CINGHIA 16 mm

BELT WIDTH 16 mm
RIEMENBREITE 16 mm
LARGEUR DE LA COURROIE 16 mm
ANCHO DE LA CORREA 16 mm

STOCK	COD	TIPO	Z	SCA	De	Df	Dm	F	L	LT	d
	PL13Z15	1F	15		45,90			22	32	34	
	PL13Z16	1F	16		49,05			22	32	34	
+	PL13Z18	1F	18	si	55,45	60	30	22	32	34	10
	PL13Z20	1F	20		61,80			22	32	34	
	PL13Z22	1F	22		68,15			22	32	34	
	PL13Z24	1F	24		74,55			22	32	34	
	PL13Z25	1F	25		77,70			22	32	34	
	PL13Z28	1F	28		87,25			22	32	34	
	PL13Z30	1F	30		93,65			22	32	34	
	PL13Z32	1F	32		100,00			22	32	34	
	PL13Z35	1F	35		109,55			22	32	34	
	PL13Z40	1F	40		125,45			22	32	34	

PULEGGE dentate

con Passo in Pollici

Timing belt pulleys inch pitch
 Zahnriemenscheiben Inchteilung
 Poulies dentées avec pas en pouces
 Poleas dentadas con paso en pulgadas

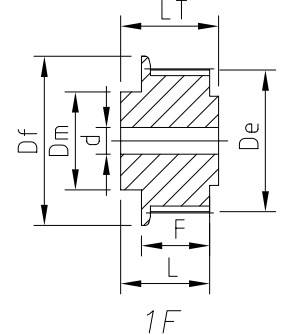

5

MXL 025

PASSO 0,080" (2,032 mm)

PITCH 0,080" (2,032 mm)
 TEILUNG 0,080" (2,032 mm)
 PAS 0,080" (2,032 mm)
 PASO 0,080" (2,032 mm)

LARGHEZZA CINGHIA 1/4" (6,35 mm)

BELT WIDTH 1/4" (6,35 mm)
 RIEMENBREITE 1/4" (6,35 mm)
 LARGEUR DE LA COURROIE 1/4" (6,35 mm)
 ANCHO DE LA CORREA 1/4" (6,35 mm)

STOCK	COD	TIPO	Z	SCA	De	Df	Dm	F	L	LT	d
+	PL21Z10	1F	10	no	5,95	12	12	9,5	17,5	19	3
+	PL21Z11	1F	11	no	6,60	12	12	9,5	17,5	19	3
+	PL21Z12	1F	12	no	7,26	12	12	9,5	17,5	19	3
+	PL21Z13	1F	13	no	7,90	12	12	9,5	17,5	19	3
+	PL21Z14	1F	14	no	8,55	12	12	9,5	17,5	19	3
+	PL21Z15	1F	15	no	9,20	12	12	9,5	17,5	19	3
+	PL21Z16	1F	16	no	9,84	12	12	9,5	17,5	19	3
+	PL21Z17	1F	17	no	10,50	12	12	9,5	17,5	19	3
+	PL21Z18	1F	18	no	11,12	15	12	9,5	17,5	19	3
+	PL21Z19	1F	19	no	11,78	15	12	9,5	17,5	19	3
+	PL21Z20	1F	20	no	12,42	16	12	9,5	17,5	19	3
+	PL21Z21	1F	21	no	13,07	16	14	9,5	17,5	19	3
+	PL21Z22	1F	22	no	13,72	18	14	9,5	17,5	19	4
+	PL21Z23	1F	23	no	14,36	18	14	9,5	17,5	19	4
+	PL21Z24	1F	24	no	15,01	20	14	9,5	17,5	19	4
+	PL21Z25	1F	25	no	15,66	20	14	9,5	17,5	19	4
+	PL21Z26	1F	26	no	16,30	20	16	9,5	17,5	19	4
+	PL21Z27	1F	27	no	16,95	20	16	9,5	17,5	19	4
+	PL21Z28	1F	28	no	17,60	22	16	9,5	17,5	19	4
+	PL21Z29	1F	29	no	18,24	22	16	9,5	17,5	19	4
+	PL21Z30	1F	30	no	18,90	24	18	9,5	17,5	19	5
+	PL21Z31	1F	31	no	19,54	24	18	9,5	17,5	19	5
+	PL21Z32	1F	32	no	20,18	24	18	9,5	17,5	19	5
+	PL21Z33	1F	33	no	20,83	26	18	9,5	17,5	19	5
	PL21Z35	1F	35		21,12			9,5	17,5	19	
	PL21Z36	1F	36		22,77			9,5	17,5	19	
	PL21Z40	1F	40		25,36			9,5	17,5	19	
	PL21Z42	1F	42		26,65			9,5	17,5	19	
	PL21Z44	1F	44		27,95			9,5	17,5	19	
+	PL21Z48	1F	48		30,53	36	24	9,5	17	19	5
+	PL21Z60	1F	60		38,30	44	30	9,5	17	19	6
	PL21Z65	1F	65		41,53			9,5	17	19	
	PL21Z72	1F	72		46,05			9,5	17	19	
	PL21Z80	1F	80		51,24			9,5	17	19	
	PL21Z90	1F	90		57,70			9,5	17	19	
	PL21Z100	1F	100		64,17			9,5	17	19	
	PL21Z110	1F	110		70,64			9,5	17	19	
+	PL21Z120	1F	120		77,10	81	40	9,5	17	19	
+	PL21Z130	1F	130		83,57	87	46	9,5	17	19	

XL 037

PASSO 1/5" (5,08 mm)

PITCH 1/5" • TEILUNG 1/5" (5,08 mm)

PAS 1/5" • PASO 1/5" (5,08 mm)

LARGHEZZA CINGHIA 3/8" (9,53 mm)

BELT WIDTH 3/8" • RIEMENBREITE 3/8" (9,53 mm)

LARGEUR DE LA COURROIE 3/8" • ANCHO DE LA CORREA 3/8" (9,53 mm)

STOCK	COD	TIPO	Z	SCA	De	Df	Dm	F	L	LT	d
	PL22Z10	1F	10		15,67			15,3	23	25	
	PL22Z11	1F	11		17,30			15,3	23	25	
	PL22Z12	1F	12		18,90	28	16	15,3	23	25	
+	PL22Z13	1F	13		20,51	28	16	15,3	23	25	
+	PL22Z14	1F	14	no	22,13	28	16	15,3	23	25	3
+	PL22Z15	1F	15	no	23,75	28	16	15,3	23	25	3
+	PL22Z16	1F	16	no	25,36	30	16	15,3	23	25	5
+	PL22Z17	1F	17	no	26,98	32	18	15,3	23	25	5
+	PL22Z18	1F	18	no	28,60	36	20	15,3	23	25	6
+	PL22Z19	1F	19	no	30,21	36	22	15,3	23	25	6
+	PL22Z20	1F	20	no	31,83	38	22	15,3	23	25	6
+	PL22Z21	1F	21	no	33,45	38	24	15,3	23	25	6
+	PL22Z22	1F	22	no	35,07	42	24	15,3	23	25	6
	PL22Z23	1F	23		36,70			15,3	23	25	
+	PL22Z24	1F	24	no	38,30	44	25	15,3	23	25	8
+	PL22Z25	1F	25	no	39,91	44	25	15,3	23	25	8
+	PL22Z27	1F	27	no	43,16	50	28	15,3	23	25	8
+	PL22Z28	1F	28		44,77	50	28	15,3	23	25	10
+	PL22Z30	1F	30	no	48,00	54	30	15,3	23	25	10
	PL22Z32	1F	32		51,24			15,3	23	25	
	PL22Z34	1F	34		54,47			15,3	23	25	
+	PL22Z35	1F	35	si	56,09	63	35	15,3	23	25	10
+	PL22Z40	1F	40	si	64,17	74	35	15,3	23	25	10
+	PL22Z42	1F	42	si	67,41	75	35	15,3	23	25	10
+	PL22Z48	1F	48	si	77,11	85	36	15,3	23	25	
+	PL22Z60	1F	60	si	96,51	103	50	15,3	23	25	19
+	PL22Z72	1F	72	si	115,91	122	50	15,3	23	25	

L 050

PASSO 3/8" (9,52 mm)

PITCH 3/8" • TEILUNG 3/8" (9,52 mm)

PAS 3/8" • PASO 3/8" (9,52 mm)

LARGHEZZA CINGHIA 1/2" (12,7 mm)

BELT WIDTH 1/2" • RIEMENBREITE 1/2" (12,7 mm)

LARGEUR DE LA COURROIE 1/2" • ANCHO DE LA CORREA 1/2" (12,7 mm)

STOCK	COD	TIPO	Z	SCA	De	Df	Dm	F	L	LT	d
+	PL23Z12	1F	12	no	35,62	42	24	20	33	35	8
+	PL23Z13	1F	13	no	38,65	44	24	20	33	35	8
	PL23Z14	1F	14		41,68			20	33	35	
+	PL23Z15	1F	15	no	44,72	50	30	20	33	35	10
+	PL23Z16	1F	16	no	47,75	54	30	20	33	35	10
+	PL23Z17	1F	17	si	50,78	57	30	20	33	35	10
	PL23Z18	1F	18		53,80			20	33	35	
	PL23Z20	1F	20		59,86			20	33	35	
+	PL23Z21	1F	21	si	62,91	71	35	20	33	35	10
	PL23Z22	1F	22		65,92			20	33	35	
	PL23Z24	1F	24		71,99			20	33	35	
+	PL23Z25	1F	25	si	75,01	84	40	20	33	35	10
	PL23Z28	1F	28		84,10			20	33	35	
	PL23Z30	1F	30		90,17			20	33	35	
	PL23Z32	1F	32		96,22			20	33	35	
	PL23Z35	1F	35		105,35			20	33	35	
	PL23Z36	1F	36		108,35			20	33	35	
	PL23Z40	1F	40		120,40			20	33	35	
	PL23Z60	1F	60		181,10			20	33	35	

L 075

PASSO 3/8" (9,52 mm)

PITCH 3/8" (9,52 mm)

TEILUNG 3/8" (9,52 mm)

PAS 3/8" (9,52 mm)

PASO 3/8" (9,52 mm)

LARGHEZZA CINGHIA 3/4" (19,05 mm)

BELT WIDTH 3/4" (19,05 mm)

RIEMENBREITE 3/4" (19,05 mm)

LARGEUR DE LA COURROIE 3/4" (19,05 mm)

ANCHO DE LA CORREA 3/4" (19,05 mm)

STOCK	COD	TIPO	Z	SCA	De	Df	Dm	F	L	LT	d
+	PL24Z12	1F	12	no	35,62	42	25	26,4	40	42	6
	PL24Z14	1F	14		41,68			26,4	40	42	
	PL24Z15	1F	15		44,72			26,4	40	42	
	PL24Z16	1F	16		47,75			26,4	40	42	
	PL24Z17	1F	17		50,78			26,4	40	42	
	PL24Z18	1F	18		53,80			26,4	40	42	
	PL24Z19	1F	19		56,83			26,4	40	42	
	PL24Z20	1F	20		59,86			26,4	40	42	
	PL24Z22	1F	22		65,92			26,4	40	42	
	PL24Z24	1F	24		71,99			26,4	40	42	
	PL24Z25	1F	25		75,01			26,4	40	42	
	PL24Z28	1F	28		84,10			26,4	40	42	
	PL24Z30	1F	30		90,17			26,4	40	42	
	PL24Z32	1F	32		96,22			26,4	40	42	
	PL24Z35	1F	35		105,35			26,4	40	42	
	PL24Z40	1F	40		120,40			26,4	40	42	
+	PL24Z60	1F	60	si	181,10	188	60	26,4	40	42	19

L 100

PASSO 3/8" (9,52 mm)

PITCH 3/8" (9,52 mm)

TEILUNG 3/8" (9,52 mm)

PAS 3/8" (9,52 mm)

PASO 3/8" (9,52 mm)

LARGHEZZA CINGHIA 1" (25,4 mm)

BELT WIDTH 1" (25,4 mm)

RIEMENBREITE 1" (25,4 mm)

LARGEUR DE LA COURROIE 1" (25,4 mm)

ANCHO DE LA CORREA 1" (25,4 mm)

STOCK	COD	TIPO	Z	SCA	De	Df	Dm	F	L	LT	d
+	PL25Z12	1F	12	no	35,62	42	25	32,8	46	48	8
+	PL25Z14	1F	14	no	41,68	48	30	32,8	46	48	8
	PL25Z15	1F	15		44,72			32,8	46	48	
	PL25Z16	1F	16		47,75			32,8	46	48	
+	PL25Z17	1F	17	si	50,78	57	30	32,8	46	48	10
+	PL25Z18	1F	18	si	53,80	60	35	32,8	46	48	10
+	PL25Z19	1F	19	si	56,83	63	35	32,8	46	48	10
	PL25Z20	1F	20		59,86			32,8	46	48	
	PL25Z21	1F	21		62,90			32,8	46	48	
	PL25Z22	1F	22		65,92			32,8	46	48	
	PL25Z24	1F	24		71,99			32,8	46	48	
	PL25Z25	1F	25		75,01			32,8	46	48	
	PL25Z28	1F	28		84,10			32,8	46	48	
	PL25Z30	1F	30		90,17			32,8	46	48	
	PL25Z32	1F	32		96,22			32,8	46	48	
	PL25Z35	1F	35		105,35			32,8	46	48	
	PL25Z40	1F	40		120,40						

H 075

PASSO 1/2" (12,7 mm)

PITCH 1/2" (12,7 mm)

TEILUNG 1/2" (12,7 mm)

PAS 1/2" (12,7 mm)

PASO 1/2" (12,7 mm)

LARGHEZZA CINGHIA 3/4" (19,05 mm)

BELT WIDTH 3/4" (19,05 mm)

RIEMENBREITE 3/4" (19,05 mm)

LARGEUR DE LA COURROIE 3/4" (19,05 mm)

ANCHO DE LA CORREA 3/4" (19,05 mm)

STOCK	COD	TIPO	Z	SCA	De	Df	Dm	F	L	LT	d
+	PL26Z14	1F	14	no	55,22	63	40	26,4	40	42	12
	PL26Z15	1F	15		59,27			26,4	40	42	
	PL26Z16	1F	16		63,31			26,4	40	42	
+	PL26Z17	1F	17	si	67,35	75	45	26,4	40	42	16
	PL26Z18	1F	18		71,39			26,4	40	42	
+	PL26Z19	1F	19	si	75,44	83	45	26,4	40	42	16
	PL26Z20	1F	20		79,48			26,4	40	42	
+	PL26Z22	1F	22	si	87,56	94	45	26,4	40	42	16
	PL26Z24	1F	24		95,65			26,4	40	42	
	PL26Z25	1F	25		99,69			26,4	40	42	
	PL26Z28	1F	28		111,82			26,4	40	42	
	PL26Z30	1F	30		119,90			26,4	40	42	
	PL26Z32	1F	32		127,99			26,4	40	42	
	PL26Z35	1F	35		140,12			26,4	40	42	
	PL26Z40	1F	40		160,33			26,4	40	42	

H 100

PASSO 1/2" (12,7 mm)

PITCH 1/2" (12,7 mm)

TEILUNG 1/2" (12,7 mm)

PAS 1/2" (12,7 mm)

PASO 1/2" (12,7 mm)

LARGHEZZA CINGHIA 1" (25,4 mm)

BELT WIDTH 1" (25,4 mm)

RIEMENBREITE 1" (25,4 mm)

LARGEUR DE LA COURROIE 1" (25,4 mm)

ANCHO DE LA CORREA 1" (25,4 mm)

STOCK	COD	TIPO	Z	SCA	De	Df	Dm	F	L	LT	d
+	PL27Z14	1F	14	no	55,22	63	40	32,8	46	48	12
+	PL27Z15	1F	15	no	59,27	67	40	32,8	46	48	14
	PL27Z16	1F	16		63,31			32,8	46	48	
	PL27Z18	1F	18		71,39			32,8	46	48	
+	PL27Z20	1F	20	si	79,48	87	45	32,8	46	48	18
+	PL27Z21	1F	21	si	83,52	91	45	32,8	46	48	18
	PL27Z22	1F	22		87,56			32,8	46	48	
	PL27Z24	1F	24		95,65			32,8	46	48	
+	PL27Z25	1F	25	si	99,69	106	50	32,8	46	48	18
	PL27Z28	1F	28		111,82			32,8	46	48	
	PL27Z30	1F	30		119,90			32,8	46	48	
	PL27Z32	1F	32		127,99			32,8	46	48	
+	PL27Z35	1F	35		140,12	146	62	32,8	46	48	
	PL27Z40	1F	40		160,33			32,8	46	48	
	PL27Z60	1F	60		241,18			32,8	46	48	

PULEGGE dentate

Compatibili HTD

Timing belt pulleys HTD compatible
 Zahnriemenscheiben kompatibel HTD
 Poulies dentées compatibles HTD
 Poleas dentadas compatible HTD

5

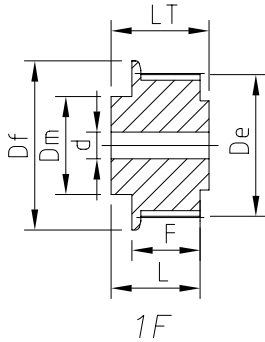

06 HTD 3M

PASSO 3 mm

PITCH 3 mm
 TEILUNG 3 mm
 PAS 3 mm
 PASO 3 mm

LARGHEZZA CINGHIA 6 mm

BELT WIDTH 6 mm
 RIEMENBREITE 6 mm
 LARGEUR DE LA COURROIE 6 mm
 ANCHO DE LA CORREA 6 mm

STOCK	COD	TIPO	Z	SCA	De	Df	Dm	F	L	LT	d
+	PL36Z10	1F	10	no	8,79	12	12	9,5	17,5	19	3
+	PL36Z11	1F	11	no	9,74	12	12	9,5	17,5	19	3
+	PL36Z12	1F	12	no	10,70	16	14	9,5	17,5	19	3
+	PL36Z13	1F	13	no	11,65	16	14	9,5	17,5	19	3
+	PL36Z14	1F	14	no	12,61	18	14	9,5	17,5	19	3
+	PL36Z15	1F	15	no	13,56	18	14	9,5	17,5	19	3
+	PL36Z16	1F	16	no	14,52	20	14	9,5	17,5	19	3
+	PL36Z17	1F	17	no	15,47	20	14	9,5	17,5	19	3
+	PL36Z18	1F	18	no	16,43	22	14	9,5	17,5	19	3
+	PL36Z19	1F	19	no	17,38	22	14	9,5	17,5	19	3
+	PL36Z20	1F	20	no	18,34	24	16	9,5	17,5	19	3
+	PL36Z21	1F	21	no	19,29	24	16	9,5	17,5	19	3
+	PL36Z22	1F	22	no	20,25	26	16	9,5	17,5	19	4
+	PL36Z23	1F	23	no	21,20	26	16	9,5	17,5	19	4
+	PL36Z24	1F	24	no	22,16	28	18	9,5	17,5	19	4
+	PL36Z25	1F	25	no	23,11	28	18	9,5	17,5	19	4
+	PL36Z26	1F	26	no	24,07	30	20	9,5	17,5	19	5
+	PL36Z27	1F	27	no	25,02	30	20	9,5	17,5	19	5
+	PL36Z28	1F	28	no	25,98	32	22	9,5	17,5	19	5
+	PL36Z29	1F	29	no	26,93	32	22	9,5	17,5	19	5
+	PL36Z30	1F	30	no	27,89	32	24	9,5	17,5	19	6
+	PL36Z31	1F	31	no	28,84	32	24	9,5	17,5	19	6
+	PL36Z32	1F	32	no	29,80	34	26	9,5	17,5	19	6
+	PL36Z33	1F	33	no	30,75	34	26	9,5	17,5	19	6
	PL36Z35	1F	35		32,66			9,5	17,5	19	
	PL36Z40	1F	40		37,43			9,5	17,5	19	
	PL36Z60	1F	60		56,53			9,5	17,5	19	

09 HTD 3M

PASSO 3 mm

PITCH 3 mm • TEILUNG 3 mm
PAS 3 mm • PASO 3 mm

LARGHEZZA CINGHIA 9 mm

BELT WIDTH 9 mm • RIEMENBREITE 9 mm
LARGEUR DE LA COURROIE 9 mm • ANCHO DE LA CORREA 9 mm

STOCK	COD	TIPO Z SCA			De	Df	Dm	F	L	LT	d
+	PL37Z10	1F	10	no	8,79	12	12	15,3	22	24	3
+	PL37Z11	1F	11	no	9,74	12	12	15,3	22	24	3
+	PL37Z12	1F	12	no	10,70	16	14	15,3	22	24	3
+	PL37Z13	1F	13	no	11,65	16	14	15,3	22	24	3
+	PL37Z14	1F	14	no	12,61	18	14	15,3	22	24	3
+	PL37Z15	1F	15	no	13,56	18	14	15,3	22	24	3
+	PL37Z16	1F	16	no	14,52	20	14	15,3	22	24	3
+	PL37Z17	1F	17	no	15,47	20	14	15,3	22	24	3
+	PL37Z18	1F	18	no	16,43	22	14	15,3	22	24	3
+	PL37Z19	1F	19	no	17,38	22	14	15,3	22	24	3
+	PL37Z20	1F	20	no	18,34	24	16	15,3	22	24	3
+	PL37Z21	1F	21	no	19,29	24	16	15,3	22	24	3
+	PL37Z22	1F	22	no	20,25	26	16	15,3	22	24	4
+	PL37Z23	1F	23	no	21,20	26	16	15,3	22	24	4
+	PL37Z24	1F	24	no	22,16	28	18	15,3	22	24	4
+	PL37Z25	1F	25	no	23,11	28	18	15,3	22	24	4
+	PL37Z26	1F	26	no	24,07	30	20	15,3	22	24	5
+	PL37Z27	1F	27	no	25,02	30	20	15,3	22	24	5
+	PL37Z28	1F	28	no	25,98	32	22	15,3	22	24	5
+	PL37Z29	1F	29	no	26,93	32	22	15,3	22	24	5
+	PL37Z30	1F	30	no	27,89	32	24	15,3	22	24	6
+	PL37Z31	1F	31	no	28,84	32	24	15,3	22	24	6
+	PL37Z32	1F	32	no	29,80	34	26	15,3	22	24	6
+	PL37Z33	1F	33	no	30,75	34	26	15,3	22	24	6
	PL37Z35	1F	35		32,66			15,3	22	24	
	PL37Z40	1F	40		37,43			15,3	22	24	
	PL37Z150	1F	150	si	142,48	174	50	15,3	22	24	19

09 HTD 5M

PASSO 5 mm

PITCH 5 mm • TEILUNG 5 mm
PAS 5 mm • PASO 5 mm

LARGHEZZA CINGHIA 9 mm

BELT WIDTH 9 mm • RIEMENBREITE 9 mm
LARGEUR DE LA COURROIE 9 mm • ANCHO DE LA CORREA 9 mm

STOCK	COD	TIPO Z SCA			De	Df	Dm	F	L	LT	d
	PL38Z12	1F	12		17,95			15,3	22	24	
	PL38Z14	1F	14		21,14			15,3	22	24	
	PL38Z15	1F	15		22,73			15,3	22	24	
	PL38Z16	1F	16		24,32			15,3	22	24	
	PL38Z18	1F	18		27,51			15,3	22	24	
+	PL38Z20	1F	20	no	30,69	36	22	15,3	22	24	6
	PL38Z22	1F	22		33,87			15,3	22	24	
	PL38Z24	1F	24		37,06			15,3	22	24	
	PL38Z25	1F	25		38,65			15,3	22	24	
	PL38Z28	1F	28		43,42			15,3	22	24	
	PL38Z30	1F	30		46,60			15,3	22	24	
	PL38Z32	1F	32		49,79			15,3	22	24	
	PL38Z35	1F	35		54,56			15,3	22	24	
+	PL38Z40	1F	40	si	62,52	71	35	15,3	22	24	12
	PL38Z48	1F	48		75,25			15,3	22	24	
	PL38Z50	1F	50		78,44			15,3	22	24	

15 HTD 5M

PASSO 5 mm

PITCH 5 mm
TEILUNG 5 mm
PAS 5 mm
PASO 5 mm

LARGHEZZA CINGHIA 15 mm

BELT WIDTH 15 mm
RIEMENBREITE 15 mm
LARGEUR DE LA COURROIE 15 mm
ANCHO DE LA CORREA 15 mm

STOCK	COD	TIPO	Z	SCA	De	Df	Dm	F	L	LT	d
	PL39Z12	1F	12		17,96			22	28	30	
	PL39Z14	1F	14		21,14			22	28	30	
	PL39Z15	1F	15		22,73			22	28	30	
	PL39Z16	1F	16		24,32			22	28	30	
	PL39Z18	1F	18		27,51			22	28	30	
	PL39Z20	1F	20		30,69			22	28	30	
	PL39Z22	1F	22		33,87			22	28	30	
+	PL39Z24	1F	24	no	37,06	42	28	22	28	30	8
	PL39Z25	1F	25		38,65			22	28	30	
+	PL39Z26	1F	26	no	40,25	46	28	22	28	30	8
	PL39Z28	1F	28		43,42			22	28	30	
	PL39Z30	1F	30		46,60			22	28	30	
+	PL39Z32	1F	32	no	49,79	57	35	22	28	30	10
	PL39Z35	1F	35		54,56			22	28	30	
	PL39Z40	1F	40		62,52			22	28	30	
	PL39Z72	1F	72		113,45			22	28	30	

25 HTD 5M

PASSO 5 mm

PITCH 5 mm
TEILUNG 5 mm
PAS 5 mm
PASO 5 mm

LARGHEZZA CINGHIA 25 mm

BELT WIDTH 25 mm
RIEMENBREITE 25 mm
LARGEUR DE LA COURROIE 25 mm
ANCHO DE LA CORREA 25 mm

STOCK	COD	TIPO	Z	SCA	De	Df	Dm	F	L	LT	d
	PL40Z12	1F	12		17,96			31	41	43	
	PL40Z14	1F	14		21,14			31	41	43	
	PL40Z15	1F	15		22,73			31	41	43	
	PL40Z16	1F	16		24,32			31	41	43	
	PL40Z18	1F	18		27,51			31	41	43	
	PL40Z20	1F	20		30,69			31	41	43	
	PL40Z22	1F	22		33,87			31	41	43	
	PL40Z24	1F	24		37,06			31	41	43	
	PL40Z25	1F	25		38,64			31	41	43	
	PL40Z28	1F	28		43,42			31	41	43	
+	PL40Z30	1F	30	no	46,60	54	30	31	41	41	10
	PL40Z32	1F	32		49,79			31	41	43	
	PL40Z35	1F	35		54,56			31	41	43	
	PL40Z40	1F	40		62,52			31	41	43	
+	PL40Z48	1F	48	si	75,25	83	35	31	41	43	8

15 HTD 8M

PASSO 8 mm

PITCH 8 mm
TEILUNG 8 mm
PAS 8 mm
PASO 8 mm

LARGHEZZA CINGHIA 15 mm

BELT WIDTH 15 mm
RIEMENBREITE 15 mm
LARGEUR DE LA COURROIE 15 mm
ANCHO DE LA CORREA 15 mm

STOCK	COD	TIPO	Z	SCA	De	Df	Dm	F	L	LT	d
	PL42Z15	1F	15	no	36,82			22	28	30	
	PL42Z16	1F	16	no	39,37			22	28	30	
	PL42Z18	1F	18	no	44,46			22	28	30	
	PL42Z20	1F	20	no	49,55			22	28	30	
	PL42Z22	1F	22	no	54,65			22	28	30	
+	PL42Z24	1F	24	si	59,74	66	38	22	28	30	12
	PL42Z25	1F	25		62,30			22	28	30	
	PL42Z28	1F	28		70,08			22	28	30	
	PL42Z30	1F	30		75,13			22	28	30	
	PL42Z32	1F	32		80,16			22	28	30	
	PL42Z35	1F	35		85,75			22	28	30	
	PL42Z40	1F	40		100,49			22	28	30	
+	PL42Z64	1F	64	si	161,6	169	60	22	28	30	20
	PL42Z100	1F	100		253,28			22	28	30	

20 HTD 8M

PASSO 8 mm

PITCH 8 mm
TEILUNG 8 mm
PAS 8 mm
PASO 8 mm

LARGHEZZA CINGHIA 20 mm

BELT WIDTH 20 mm
RIEMENBREITE 20 mm
LARGEUR DE LA COURROIE 20 mm
ANCHO DE LA CORREA 20 mm

STOCK	COD	TIPO	Z	SCA	De	Df	Dm	F	L	LT	d
	PL41Z15	1F	15	no	36,82	42	25	28	38	40	8
	PL41Z16	1F	16	no	39,37	45	30	28	38	40	8
	PL41Z18	1F	18	no	44,46	51	30	28	38	40	8
	PL41Z20	1F	20	no	49,55	54	35	28	38	40	8
	PL41Z22	1F	22	no	54,65	60	35	28	38	40	10
	PL41Z24	1F	24		59,74			28	38	40	
	PL41Z25	1F	25		62,30			28	38	40	
	PL41Z28	1F	28		70,08			28	38	40	
	PL41Z30	1F	30		75,13			28	38	40	
	PL41Z32	1F	32		80,16			28	38	40	
	PL41Z35	1F	35		85,75			28	38	40	
	PL41Z40	1F	40		100,49			28	38	40	
	PL41Z90	1F	90		227,81			28	38	40	
	PL41Z100	1F	100		253,28			28	38	40	

PULEGGE dentate

Compatibili RPP

Timing belt pulleys compatible with RPP timing belts

Zahnriemenscheiben kompatibel mit RPP Riemen

Poulies dentées compatibles avec courroie RPP

Poleas dentadas compatible con correa RPP

5

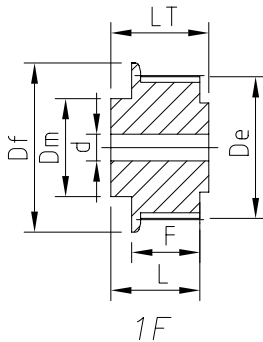

06 RPP 3M

PASSO 3 mm

PITCH 3 mm
TEILUNG 3 mm
PAS 3 mm
PASO 3 mm

LARGHEZZA CINGHIA 6 mm

BELT WIDTH 6 mm
RIEMENBREITE 6 mm
LARGEUR DE LA COURROIE 6 mm
ANCHO DE LA CORREA 6 mm

STOCK	COD	TIPO	Z	SCA	De	Df	Dm	F	L	LT	d
+	PL46Z10	1F	10	no	8,79	12	12	9,5	17	19	3
+	PL46Z11	1F	11	no	9,74	12	12	9,5	17	19	3
+	PL46Z12	1F	12	no	10,70	16	14	9,5	17	19	3
+	PL46Z13	1F	13	no	11,65	16	14	9,5	17	19	3
+	PL46Z14	1F	14	no	12,61	18	14	9,5	17	19	3
+	PL46Z15	1F	15	no	13,56	18	14	9,5	17	19	3
+	PL46Z16	1F	16	no	14,52	20	14	9,5	17	19	3
+	PL46Z17	1F	17	no	15,47	20	14	9,5	17	19	3
+	PL46Z18	1F	18	no	16,43	22	14	9,5	17	19	3
+	PL46Z19	1F	19	no	17,38	22	14	9,5	17	19	3
+	PL46Z20	1F	20	no	18,34	24	16	9,5	17	19	3
+	PL46Z21	1F	21	no	19,29	24	16	9,5	17	19	3
+	PL46Z22	1F	22	no	20,25	26	16	9,5	17	19	4
+	PL46Z23	1F	23	no	21,20	26	16	9,5	17	19	4
+	PL46Z24	1F	24	no	22,16	28	18	9,5	17	19	4
+	PL46Z25	1F	25	no	23,11	28	18	9,5	17	19	4
+	PL46Z26	1F	26	no	24,07	30	20	9,5	17	19	5
+	PL46Z27	1F	27	no	25,02	30	20	9,5	17	19	5
+	PL46Z28	1F	28	no	25,98	32	22	9,5	17	19	5
+	PL46Z29	1F	29	no	26,93	32	22	9,5	17	19	5
+	PL46Z30	1F	30	no	27,89	32	24	9,5	17	19	6
+	PL46Z31	1F	31	no	28,84	32	24	9,5	17	19	6
+	PL46Z32	1F	32	no	29,80	34	26	9,5	17	19	6
+	PL46Z33	1F	33	no	30,75	34	26	9,5	17	19	6
	PL46Z35	1F	35		32,66			9,5	17	19	
	PL46Z40	1F	40		37,43			9,5	17	19	

09 RPP 3M

PASSO 3 mm

PITCH 3 mm
TEILUNG 3 mm
PAS 3 mm
PASO 3 mm

LARGHEZZA CINGHIA 9 mm

BELT WIDTH 9 mm
RIEMENBREITE 9 mm
LARGEUR DE LA COURROIE 9 mm
ANCHO DE LA CORREA 9 mm

STOCK	COD	TIPO	Z	SCA	De	Df	Dm	F	L	LT	d
+	PL47Z10	1F	10	no	8,79	12	12	15,3	22	24	3
+	PL47Z11	1F	11	no	9,74	12	12	15,3	22	24	3
+	PL47Z12	1F	12	no	10,70	16	14	15,3	22	24	3
+	PL47Z13	1F	13	no	11,65	16	14	15,3	22	24	3
+	PL47Z14	1F	14	no	12,61	18	14	15,3	22	24	3
+	PL47Z15	1F	15	no	13,56	18	14	15,3	22	24	3
+	PL47Z16	1F	16	no	14,52	20	14	15,3	22	24	3
+	PL47Z17	1F	17	no	15,47	20	14	15,3	22	24	3
+	PL47Z18	1F	18	no	16,43	22	14	15,3	22	24	3
+	PL47Z19	1F	19	no	17,38	22	14	15,3	22	24	3
+	PL47Z20	1F	20	no	18,34	24	16	15,3	22	24	3
+	PL47Z21	1F	21	no	19,29	24	16	15,3	22	24	3
+	PL47Z22	1F	22	no	20,25	26	16	15,3	22	24	4
+	PL47Z23	1F	23	no	21,20	26	16	15,3	22	24	4
+	PL47Z24	1F	24	no	22,16	28	18	15,3	22	24	4
+	PL47Z25	1F	25	no	23,11	28	18	15,3	22	24	4
+	PL47Z26	1F	26	no	24,07	30	20	15,3	22	24	5
+	PL47Z27	1F	27	no	25,02	30	20	15,3	22	24	5
+	PL47Z28	1F	28	no	25,98	32	22	15,3	22	24	5
+	PL47Z29	1F	29	no	26,93	32	22	15,3	22	24	5
+	PL47Z30	1F	30	no	27,89	32	24	15,3	22	24	6
+	PL47Z31	1F	31	no	28,84	32	24	15,3	22	24	6
+	PL47Z32	1F	32	no	29,80	34	26	15,3	22	24	6
+	PL47Z33	1F	33	no	30,75	34	26	15,3	22	24	6
	PL47Z35	1F	35		32,66			15,3	22	24	
	PL47Z40	1F	40		37,43			15,3	22	24	
	PL47Z60	1F	60		56,53			15,3	22	24	

09 RPP 5M

PASSO 5 mm

PITCH 5 mm
TEILUNG 5 mm
PAS 5 mm
PASO 5 mm

LARGHEZZA CINGHIA 9 mm

BELT WIDTH 9 mm
RIEMENBREITE 9 mm
LARGEUR DE LA COURROIE 9 mm
ANCHO DE LA CORREA 9 mm

STOCK	COD	TIPO	Z	SCA	De	Df	Dm	F	L	LT	d
	PL48Z12	1F	12		17,96			15,3	22	24	
	PL48Z14	1F	14		21,14			15,3	22	24	
	PL48Z15	1F	15		22,72			15,3	22	24	
	PL48Z16	1F	16		24,32			15,3	22	24	
	PL48Z18	1F	18		27,51			15,3	22	24	
	PL48Z20	1F	20		30,69			15,3	22	24	
	PL48Z22	1F	22		33,87			15,3	22	24	
	PL48Z24	1F	24		37,06			15,3	22	24	
	PL48Z25	1F	25		38,64			15,3	22	24	
	PL48Z28	1F	28		43,42			15,3	22	24	
	PL48Z30	1F	30		46,60			15,3	22	24	
	PL48Z32	1F	32		49,79			15,3	22	24	
	PL48Z35	1F	35		54,56			15,3	22	24	
	PL48Z40	1F	40		62,52			15,3	22	24	

15 RPP 5M

PASSO 5 mm

PITCH 5 mm
TEILUNG 5 mm
PAS 5 mm
PASO 5 mm

LARGHEZZA CINGHIA 15 mm

BELT WIDTH 15 mm
RIEMENBREITE 15 mm
LARGEUR DE LA COURROIE 15 mm
ANCHO DE LA CORREA 15 mm

STOCK	COD	TIPO	Z	SCA	De	Df	Dm	F	L	LT	d
	PL49Z12	1F	12		17,96			22	28	30	
	PL49Z14	1F	14		21,14			22	28	30	
	PL49Z15	1F	15		22,72			22	28	30	
	PL49Z16	1F	16		24,32			22	28	30	
	PL49Z18	1F	18		27,51			22	28	30	
	PL49Z20	1F	20		30,69			22	28	30	
	PL49Z22	1F	22		33,87			22	28	30	
	PL49Z24	1F	24		37,06			22	28	30	
	PL49Z25	1F	25		38,64			22	28	30	
	PL49Z28	1F	28		43,42			22	28	30	
	PL49Z30	1F	30		46,60			22	28	30	
	PL49Z32	1F	32		49,79			22	28	30	
	PL49Z35	1F	35		54,56			22	28	30	
	PL49Z40	1F	40		62,52			22	28	30	

25 RPP 5M

PASSO 5 mm

PITCH 5 mm
TEILUNG 5 mm
PAS 5 mm
PASO 5 mm

LARGHEZZA CINGHIA 25 mm

BELT WIDTH 25 mm
RIEMENBREITE 25 mm
LARGEUR DE LA COURROIE 25 mm
ANCHO DE LA CORREA 25 mm

STOCK	COD	TIPO	Z	SCA	De	Df	Dm	F	L	LT	d
	PL50Z12	1F	12		17,96			31	41	43	
	PL50Z14	1F	14		21,14			31	41	43	
	PL50Z15	1F	15		22,72			31	41	43	
	PL50Z16	1F	16		24,32			31	41	43	
	PL50Z18	1F	18		27,51			31	41	43	
	PL50Z20	1F	20		30,69			31	41	43	
	PL50Z22	1F	22		33,87			31	41	43	
	PL50Z24	1F	24		37,06			31	41	43	
	PL50Z25	1F	25		38,64			31	41	43	
	PL50Z28	1F	28		43,42			31	41	43	
	PL50Z30	1F	30		46,60			31	41	43	
	PL50Z32	1F	32		49,79			31	41	43	
	PL50Z35	1F	35		54,56			31	41	43	
	PL50Z40	1F	40		62,52			31	41	43	

15 RPP 8M

PASSO 8 mm

PITCH 8 mm
TEILUNG 8 mm
PAS 8 mm
PASO 8 mm

LARGHEZZA CINGHIA 15 mm

BELT WIDTH 15 mm
RIEMENBREITE 15 mm
LARGEUR DE LA COURROIE 15 mm
ANCHO DE LA CORREA 15 mm

STOCK	COD	TIPO	Z	SCA	De	Df	Dm	F	L	LT	d
	PL52Z22	1F	22		54,65			22	28	30	
	PL52Z24	1F	24		59,74			22	28	30	
	PL52Z25	1F	25		62,30			22	28	30	
	PL52Z28	1F	28		70,08			22	28	30	
	PL52Z30	1F	30		75,13			22	28	30	
	PL52Z32	1F	32		80,16			22	28	30	
	PL52Z35	1F	35		87,75			22	28	30	
	PL52Z40	1F	40		100,49			22	28	30	

20 RPP 8M

PASSO 8 mm

PITCH 8 mm
TEILUNG 8 mm
PAS 8 mm
PASO 8 mm

LARGHEZZA CINGHIA 20 mm

BELT WIDTH 20 mm
RIEMENBREITE 20 mm
LARGEUR DE LA COURROIE 20 mm
ANCHO DE LA CORREA 20 mm

STOCK	COD	TIPO	Z	SCA	De	Df	Dm	F	L	LT	d
	PL51Z22	1F	22		54,65			28	38	40	
	PL51Z24	1F	24		59,74			28	38	40	
	PL51Z25	1F	25		62,30			28	38	40	
	PL51Z28	1F	28		70,08			28	38	40	
	PL51Z30	1F	30		75,13			28	38	40	
	PL51Z32	1F	32		80,16			28	38	40	
	PL51Z35	1F	35		87,75			28	38	40	
	PL51Z40	1F	40		100,49			28	38	40	

PULEGGE serie Americana

Timing Belt Pulleys with American dimensions
 Zahnriemenscheiben in der Ausführung mit amerikanischen Massen
 Poulies avec dimensions américaines
 Polea en medida americana



MXL 025

PASSO 0,080" (2,032 mm)

PITCH 0,080" (2,032 mm)
 TEILUNG 0,080" (2,032 mm)
 PAS 0,080" (2,032 mm)
 PASO 0,080" (2,032 mm)

LARGHEZZA CINGHIA 1/4" (6,35 mm)

BELT WIDTH 1/4" (6,35 mm)
 RIEMENBREITE 1/4" (6,35 mm)
 LARGEUR DE LA COURROIE 1/4" (6,35 mm)
 ANCHO DE LA CORREA 1/4" (6,35 mm)

STOCK	COD	TIPO	Z	SCA	De	Df	Dm	F	L	LT	d
+	PL52Z18	1F	18	no	11,1	16	13	9,7	16	17,5	6
+	PL52Z20	1F	20	no	12,4	17	13	9,7	16	17,5	6
+	PL52Z21	1F	21	no	13,1	18	13	9,7	16	17,5	6
+	PL52Z22	1F	22	no	13,7	19	13	9,7	16	17,5	6
+	PL52Z24	1F	24	no	15	20	13	9,7	16	17,5	6
+	PL52Z28	1F	28	no	17,6	22	17,5	9,7	16	17,5	6
+	PL52Z40	1F	40	no	24,5	30	13	9,7	16	17,5	8
+	PL52Z44	1F	44	no	28	33	17,5	9,7	16	17,5	8
+	PL52Z60	1F	60	no	38,3	43	17,5	9,7	16	17,5	8
+	PL52Z65	1F	65	no	41,5	46	17,5	9,7	16	17,5	8

XL 037

PASSO 1/5" (5,08 mm)

PITCH 1/5" (5,08 mm)
 TEILUNG 1/5" (5,08 mm)
 PAS 1/5" (5,08 mm)
 PASO 1/5" (5,08 mm)

LARGHEZZA CINGHIA 3/8" (9,53 mm)

BELT WIDTH 3/8" (9,53 mm)
 RIEMENBREITE 3/8" (9,53 mm)
 LARGEUR DE LA COURROIE 3/8" (9,53 mm)
 ANCHO DE LA CORREA 3/8" (9,53 mm)

STOCK	COD	TIPO	Z	SCA	De	Df	Dm	F	L	LT	d
+	PL53Z11	1F	11	no	17,3	24	17,5	12,8	19,1	20,6	4
+	PL53Z13	1F	13	no	20,5	27	17,5	12,8	19,1	20,6	5
+	PL53Z20	1F	20	no	31,8	38	22	12,8	19,1	20,6	8
+	PL53Z24	1F	24	no	38,3	45	22	12,8	19,1	20,6	8
+	PL53Z25	1F	25	no	39,9	46	22	12,8	19,1	20,6	8
+	PL53Z26	1F	26	no	41,6	48	22	12,8	19,1	20,6	6
+	PL53Z27	1F	27	no	43,2	50	22	12,8	19,1	20,6	8
+	PL53Z30	1F	30	si	48	54	22	12,8	19,1	20,6	8

PULEGGE tendi cinghia

Timing belt pulleys
Zahnriemenscheiben
Poulies pour courroies dentées
Poleas para correa dentadas

5

PTGT

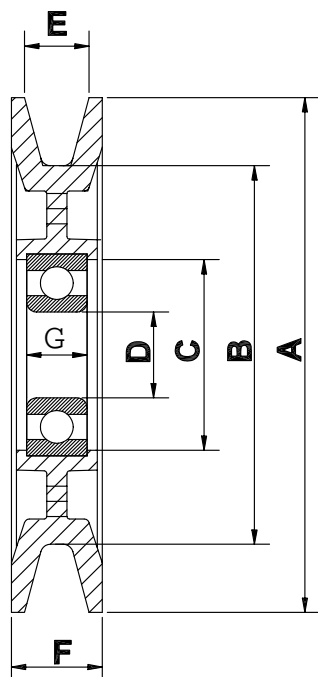

PTGP

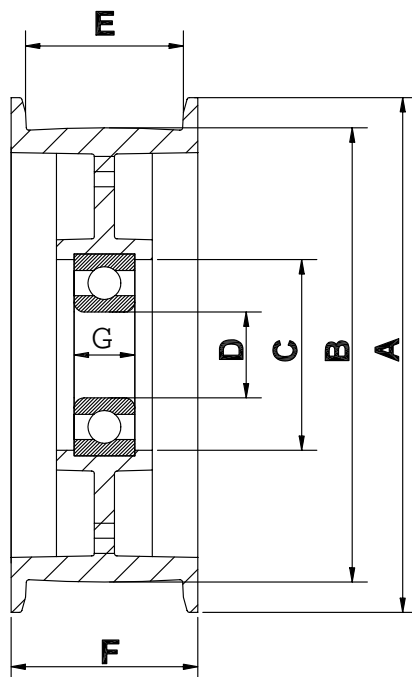

PTGR

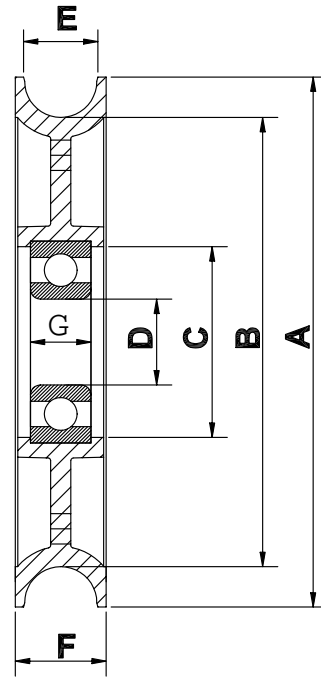

PTGT

COD	A	B	C	D	E	F	G
PTGT 49 13 17	76	49	38	17	13,3	18	12
PTGT 75 13 17	102	75	38	17	12,8	18	12
PTGT 96 15 17	127	96	38	17	15,8	21	12

PTGP

COD	A	B	C	D	E	F	G
PTGP 30 9 8	40	30	20	8	9,2	13,2	7
PTGP 32 13 8	42	32	22	8	13,2	17,2	7
PTGP 50 18 17	62	50	38	17	18,3	22,5	12
PTGP 50 20 17	62	50	38	17	20,3	26	12
PTGP 75 25 17	87	75	38	17	25,3	29,5	12
PTGP 75 31 17	87	75	38	17	31,3	35,5	12
PTGP 75 31 17D	87	75	38	17	31,3	35,5	24
PTGP 90 18 17	102	90	38	17	18,3	22,5	12
PTGP 90 31 17	102	90	38	17	31,3	35,5	12
PTGP 90 31 17D	102	90	38	17	31,3	35,5	24
PTGP 90 36 17D	102	90	38	17	36,3	40,5	24
PTGP 115 36 17	127	115	38	17	26,6	30,5	12

PTGR

COD	A	B	C	D	E	F	G
PTGR 62 10 17	76	62	38	17	10,3	18	12
PTGR 89 14 17	105	89	38	17	14,3	18	12
PTGR 95 11 17	114	95	38	17	11,3	20	12

PULEGGIA PER CINGHIA PIANA

Pulley for flat belt
 Zahnriemenscheibe für flaches Reimen
 Poulie tendeur plate
 Polea para correa plana

5

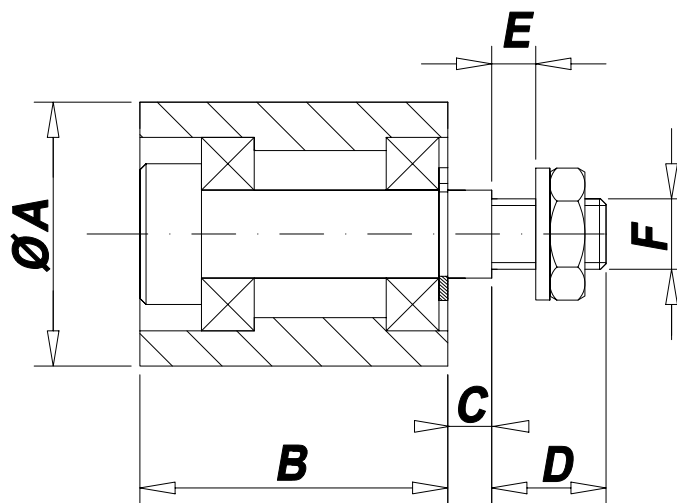

COD	A	B	C	D	E max	F
PCP 30	30	35	2	14	5	M 8
PCP 40	40	45	6	16	7	M 10
PCP 60	60	60	8	17	7	M 12